

PLAN VIEW

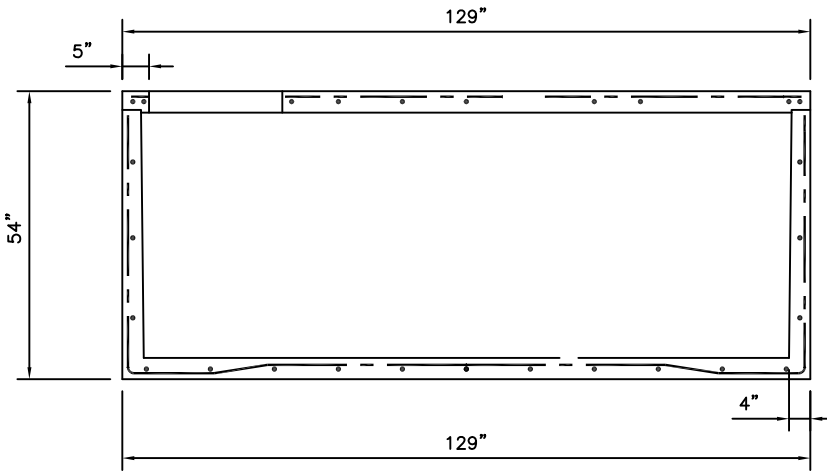

SIDE VIEW

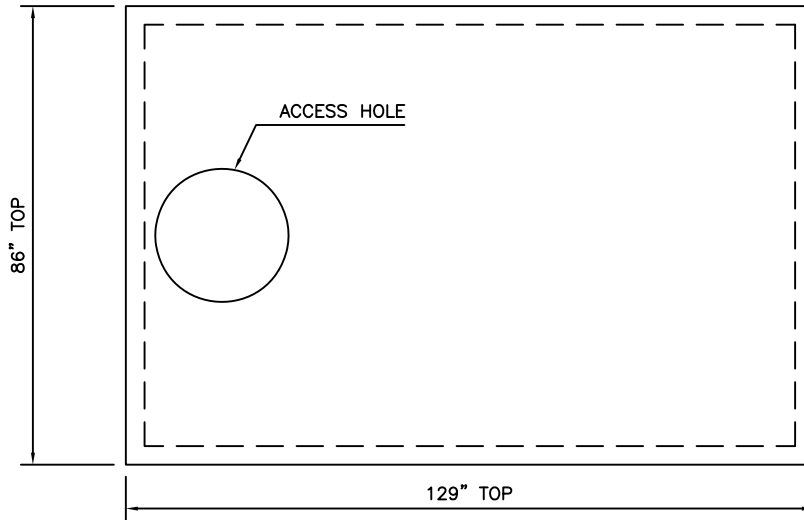
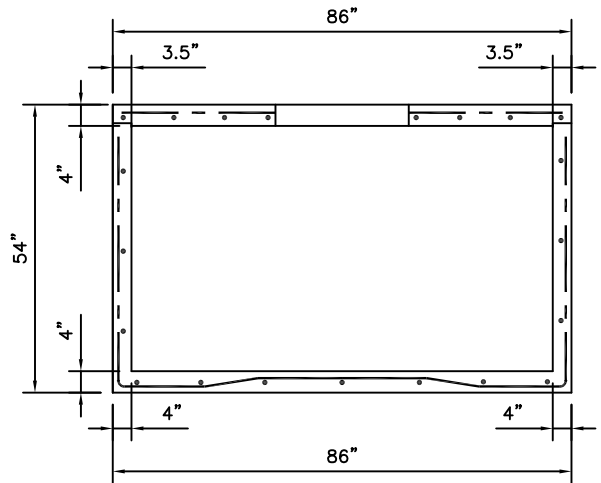

END VIEW

**General Notes:**

**Tank Volumes:**

Total Volume: 1810 gal±  
 Operating Volume: 1505 gal±  
 Average unit volume full depth : 35.8 gal./in.±  
 Unit volume at typical operating depth : 35.8 gal./in.±

**Loads:**

Top = 400 psf  
 Lateral Load = 62.4 pcf  
 Concentrated Wheel Load = 2500 lb.  
 The septic tank shall be capable of withstanding long-term hydrostatic loading, in addition to the soil loading, due to a water table maintained at ground surface.  
 Soil Bearing = 1500 psf (re-evaluate support base if soil bearing is less or unequal)

**Concrete:**

The walls and bottom slab shall be poured monolithically.  
 Reinforcing steel shall be ASTM A-615 Grade 60, fy = 60,000 psi.  
  
 The concrete shall achieve a minimum compressive strength of 4,000 psi in 28 days; fc' = 4,000 psi. Concrete shall be ready mix with cement conforming to ASTM C-150, Type II. There shall be a content of not less than six and one half (6 1/2) sacks per cubic yards and maximum aggregate size of 3/4 inch.  
 Water/Cement ratio shall be kept below 0.4, (W:C 0.35±). Air-entraining agents and fibrous reinforcement will enhance workability, curing and watertightness of the tank; however, their usage is optional.

Tanks shall not be moved from the manufacturing site to the job site until the tank has cured for seven (7) days, or has reached two-thirds of the design strength. Proper curing techniques must be used to ensure watertight tanks.

**Installation:**

Installation, bedding, compaction, etc., shall be in strict compliance with the manufacturers standards and state of Oregon's on-site rules 340-71 and 73. All tanks shall be set level on a minimum 3 inch thick compacted sand or approved granular bedding overlying a firm uniform base. The base shall be stable and uniform in order to ensure equal bearing across the tank bottom. Installations with 20 inches or less of ground cover may require additional buoyancy considerations as described in the manufacturers instructions. A minimum cover of 12 inches is required over the tank in areas subject to occasional light wheel loads.

**Test:**

Tanks shall be tested and certified watertight per Oregon On-Site Rules 340-71 and 73.

**Tank Markings:**

Place marking on the upper most surface over the outlet.  
 Liquid capacity: 1500 gal.  
 Max burial depth: 4ft.  
 Max traffic (wheel): 2500 lbs.  
 Date manufactured:  
 Permit no.:

**ADVANTAGE PRECAST** I N C.

1302 Candlewood Dr N      Voice: (503) 390-2048  
 Keizer, Oregon 97303      Fax: (503) 390-1645  
 www.advantageprecast.com

"A Locally Owned Small Business, Where Service Comes First."



**STANDARD 1750 GALLON  
 POTABLE WATER TANK**

Concrete: 4000psi +

Weight: Approx. 13,650 lb.

DATE:

July 2009