

GRATES
H-20 Rated, 65 LBS

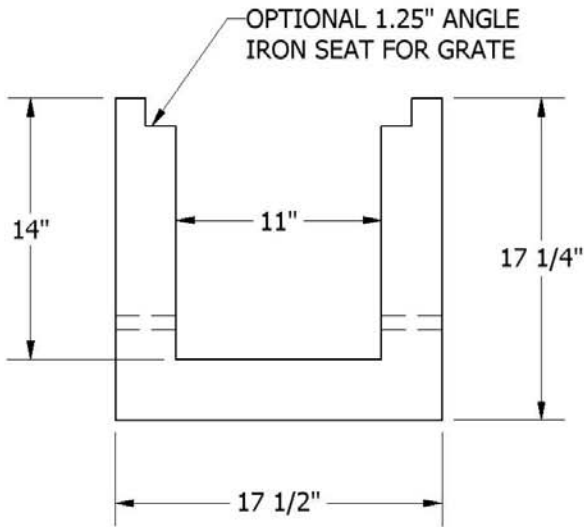

*(RESIDENTIAL CHANNEL DRAIN & SMALLER COMMERCIAL CHANNEL DRAIN ALSO AVAILABLE.)

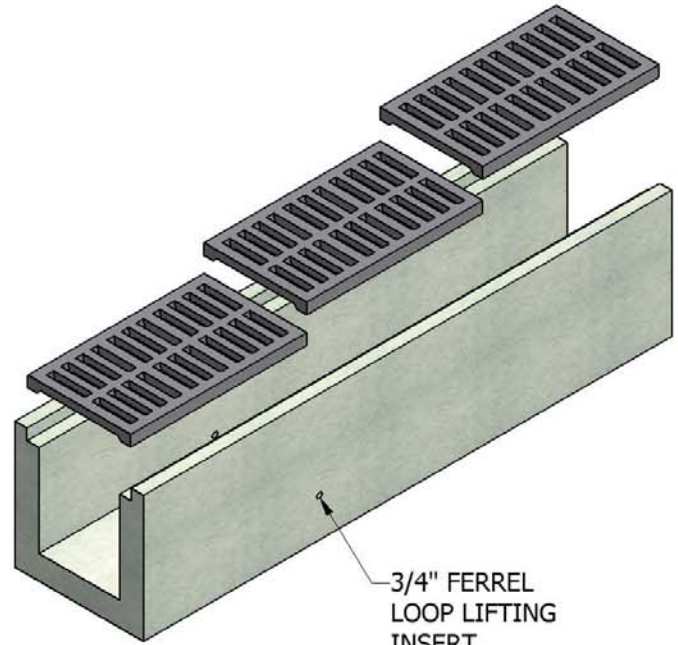
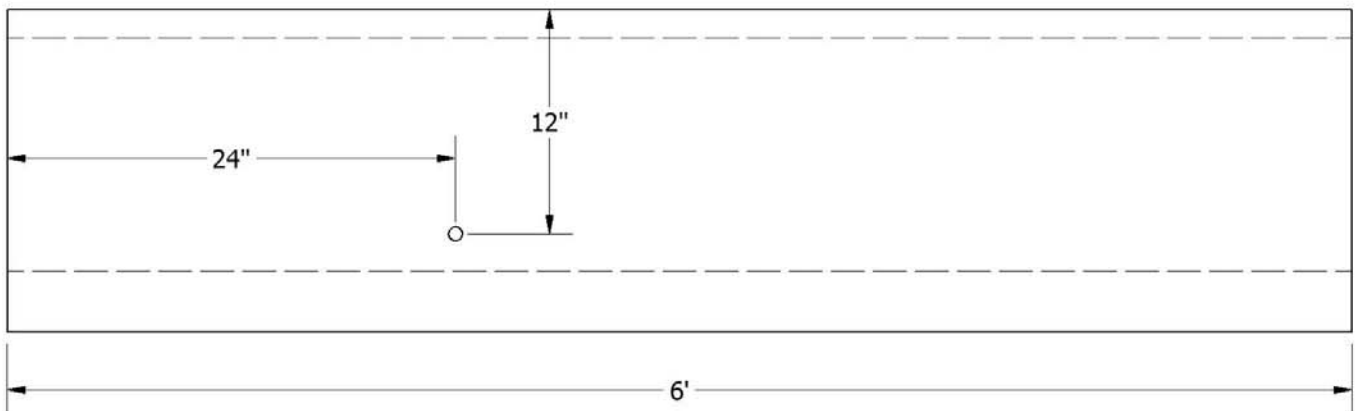

ADVANTAGE PRECAST I. C.

1302 Candlewood Dr N Voice: (503) 390-2048
Keizer, Oregon 97303 Fax: (503) 390-1645
<http://www.AdvantagePrecast.com>

"A Locally Owned Small Business, Where Service Comes First."



COMMERCIAL CHANNEL DRAIN

Concrete: **4000psi +**
Weight:

DATE:
Oct. 2006